

appel

KNIVES

PLOTTERZUBEHÖR

CUCHILLAS PLÓTER

2024

ZÜND

ESKO-Kongsberg

Aristo

Lasercomb

Elcede - Otros

appel

Plotter supplies

Plotterzubehör

Cuchillas Plóter

[www.appelgroup.eu](http://www.appelgroup.eu)

# ZÜND



REF 2024

appel

Zünd



ACZ0200

Code / Andere Bezeichnung / Código similar	Typ 2 32
Depth of bevel / Schneidtiefe / Profundidad corte	2,7 / 4,9
Length / Länge / Largo	51.5
Width / Breite / Ancho	5.7
Thickness / Stärke / Espesor	0.63
Bevel / Schneide / Ángulo	90° / 45°
Material / Werkstoff / Material	Acero
Packing unit / VE /Unidad de Venta	10

TC = Tungsteno Carburo

Code / Andere Bezeichnung / Código similar	Typ 3 746
Depth of bevel / Schneidtiefe / Profundidad corte	2,7 / 7,8
Length / Länge / Largo	51.5
Width / Breite / Ancho	5.7
Thickness / Stärke / Espesor	0.63
Bevel / Schneide / Ángulo	90° / 54°
Material / Werkstoff / Material	Acero
Packing unit / VE /Unidad de Venta	10

TC = Tungsteno Carburo

Zünd



ACZ0201

appel

Zünd

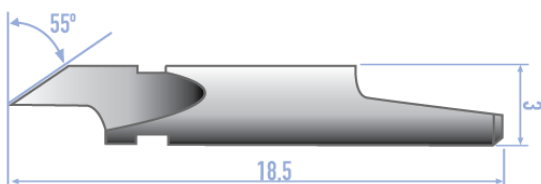

ACZ0400

Code / Andere Bezeichnung / Código similar	Z4
Depth of bevel / Schneidtiefe / Profundidad corte	2.1
Length / Länge / Largo	18.5
Width / Breite / Ancho	3
Thickness / Stärke / Espesor	
Bevel / Schneide / Ángulo	55°
Material / Werkstoff / Material	TC / VHM
Packing unit / VE /Unidad de Venta	10

TC = Tungsteno Carburo

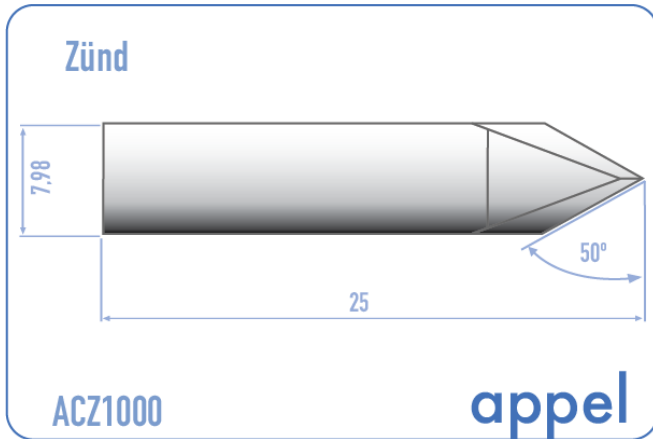

Code / Andere Bezeichnung / Código similar	Z10
Depth of bevel / Schneidtiefe / Profundidad corte	4.8
Length / Länge / Largo	25
Width / Breite / Ancho	8
Thickness / Stärke / Espesor	1.5
Bevel / Schneide / Ángulo	50°
Material / Werkstoff / Material	TC / VHM
Packing unit / VE / Unidad de Venta	2

TC = Tungsteno Carburo

Code / Andere Bezeichnung / Código similar	Z11
Depth of bevel / Schneidtiefe / Profundidad corte	6.5
Length / Länge / Largo	50
Width / Breite / Ancho	8
Thickness / Stärke / Espesor	1.5
Bevel / Schneide / Ángulo	60°
Material / Werkstoff / Material	TC + TiAlN / VHM
Packing unit / VE / Unidad de Venta	2

TC = Tungsteno Carburo

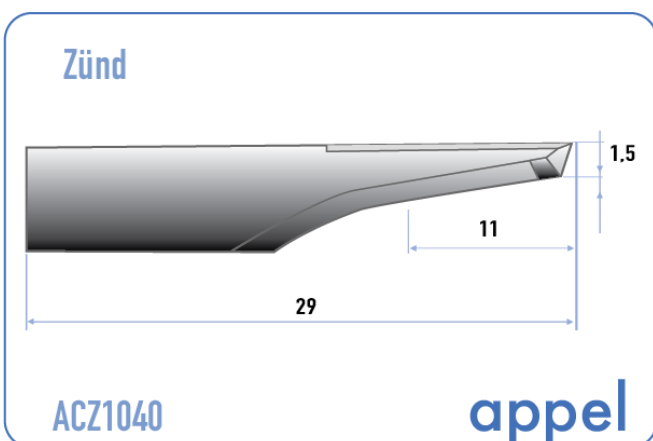
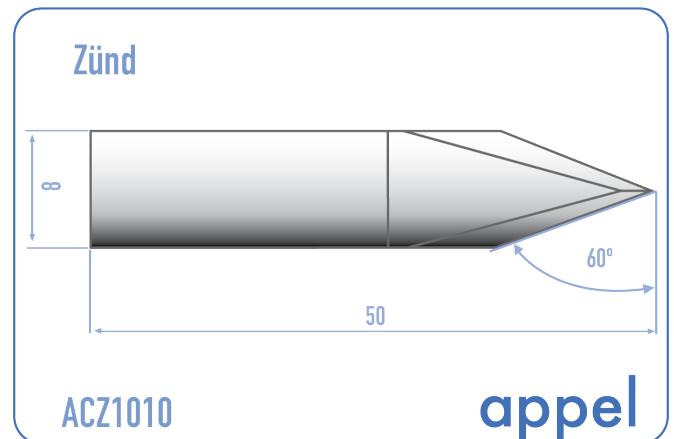

Code / Andere Bezeichnung / Código similar	Z104
Depth of bevel / Schneidtiefe / Profundidad corte	11
Length / Länge / Largo	29
Width / Breite / Ancho	
Thickness / Stärke / Espesor	
Bevel / Schneide / Ángulo	
Material / Werkstoff / Material	TC
Packing unit / VE / Unidad de Venta	10

TC = Tungsteno Carburo

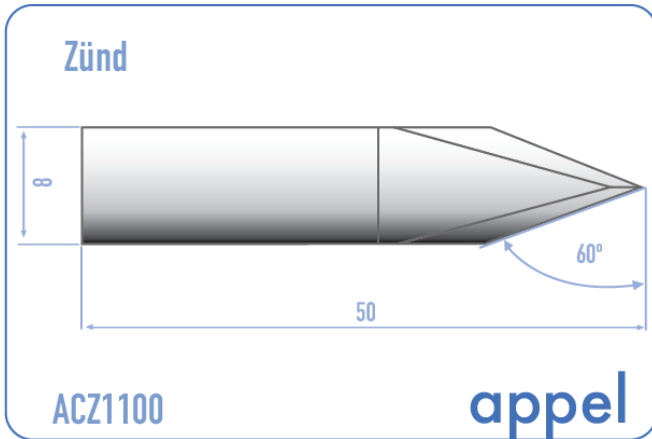

Code / Andere Bezeichnung / Código similar	Z11
Depth of bevel / Schneidtiefe / Profundidad corte	6.5
Length / Länge / Largo	50
Width / Breite / Ancho	8
Thickness / Stärke / Espesor	1.5
Bevel / Schneide / Ángulo	60°
Material / Werkstoff / Material	TC / VHM
Packing unit / VE / Unidad de Venta	2

TC = Tungsteno Carburo

Code / Andere Bezeichnung / Código similar	Z12
Depth of bevel / Schneidtiefe / Profundidad corte	4.8
Length / Länge / Largo	50
Width / Breite / Ancho	8
Thickness / Stärke / Espesor	1.5
Bevel / Schneide / Ángulo	2 x 50°
Material / Werkstoff / Material	TC / VHM
Packing unit / VE / Unidad de Venta	2

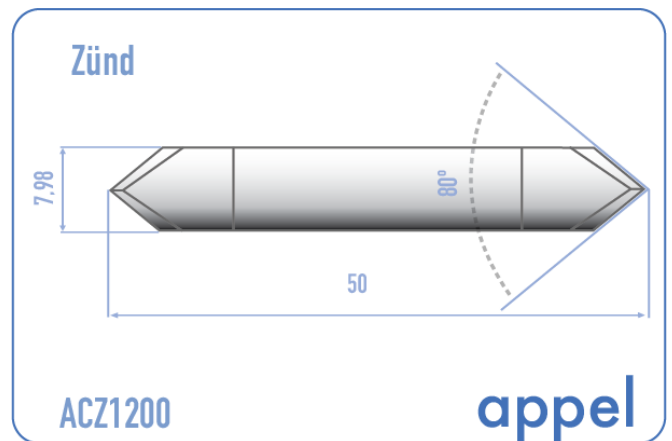

TC = Tungsteno Carburo

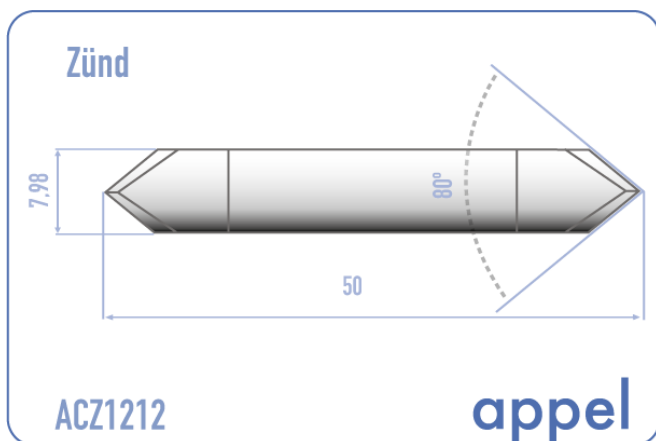

Code / Andere Bezeichnung / Código similar	Z12
Depth of bevel / Schneidtiefe / Profundidad corte	4.8
Length / Länge / Largo	50
Width / Breite / Ancho	8
Thickness / Stärke / Espesor	1.5
Bevel / Schneide / Ángulo	2 x 50°
Material / Werkstoff / Material	TC + TiAlN / VHM
Packing unit / VE / Unidad de Venta	2

TC = Tungsteno Carburo

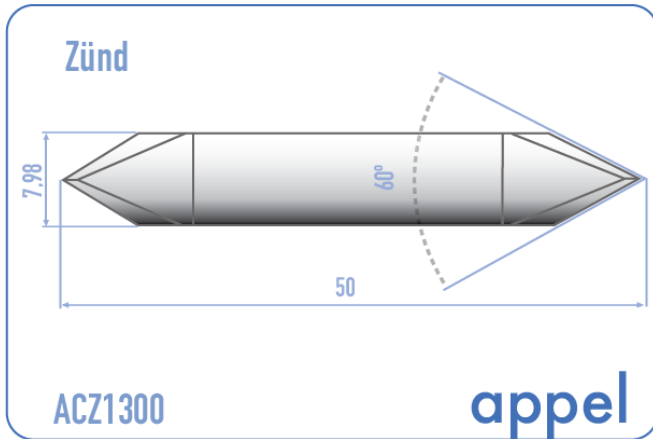

Code / Andere Bezeichnung / Código similar	Z13
Depth of bevel / Schneidtiefe / Profundidad corte	6.9
Length / Länge / Largo	50
Width / Breite / Ancho	8
Thickness / Stärke / Espesor	1.5
Bevel / Schneide / Ángulo	2 x 60°
Material / Werkstoff / Material	TC / VHM
Packing unit / VE / Unidad de Venta	2

TC = Tungsteno Carburo

Code / Andere Bezeichnung / Código similar	Z13
Depth of bevel / Schneidtiefe / Profundidad corte	6.9
Length / Länge / Largo	50
Width / Breite / Ancho	8
Thickness / Stärke / Espesor	1.5
Bevel / Schneide / Ángulo	2 x 60°
Material / Werkstoff / Material	TC + TiAlN / VHM
Packing unit / VE / Unidad de Venta	2

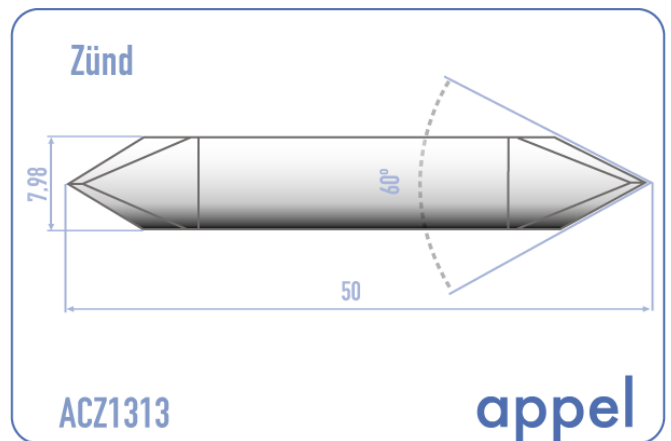

TC = Tungsteno Carburo

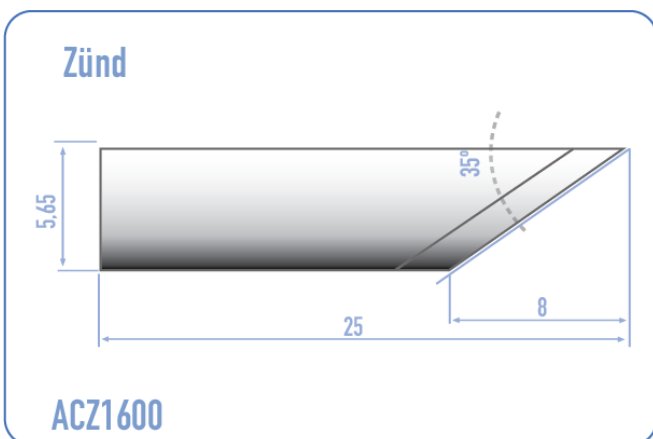

Code / Andere Bezeichnung / Código similar	Z16
Depth of bevel / Schneidtiefe / Profundidad corte	7.4
Length / Länge / Largo	25
Width / Breite / Ancho	5.65
Thickness / Stärke / Espesor	0.64
Bevel / Schneide / Ángulo	35°
Material / Werkstoff / Material	TC / VHM
Packing unit / VE / Unidad de Venta	2

TC = Tungsteno Carburo

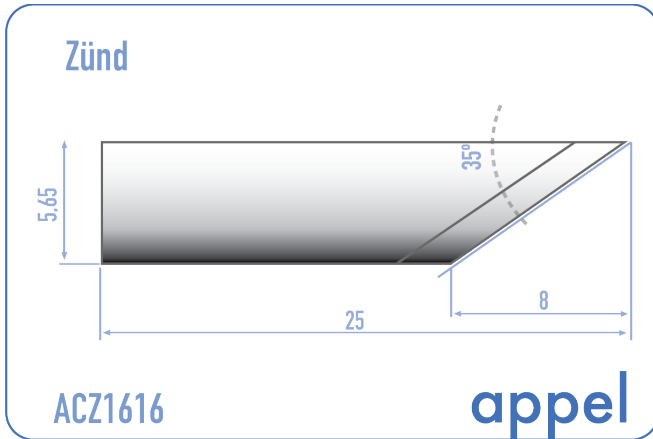

Code / Andere Bezeichnung / Código similar	Z16
Depth of bevel / Schneidtiefe / Profundidad corte	7.4
Length / Länge / Largo	25
Width / Breite / Ancho	5.65
Thickness / Stärke / Espesor	0.64
Bevel / Schneide / Ángulo	35°
Material / Werkstoff / Material	TC + TiAlN / VHM
Packing unit / VE / Unidad de Venta	2

TC = Tungsteno Carburo

Code / Andere Bezeichnung / Código similar	Z17
Depth of bevel / Schneidtiefe / Profundidad corte	12
Length / Länge / Largo	25
Width / Breite / Ancho	5.65
Thickness / Stärke / Espesor	0.64
Bevel / Schneide / Ángulo	25°
Material / Werkstoff / Material	TC / VHM
Packing unit / VE / Unidad de Venta	2

TC = Tungsteno Carburo

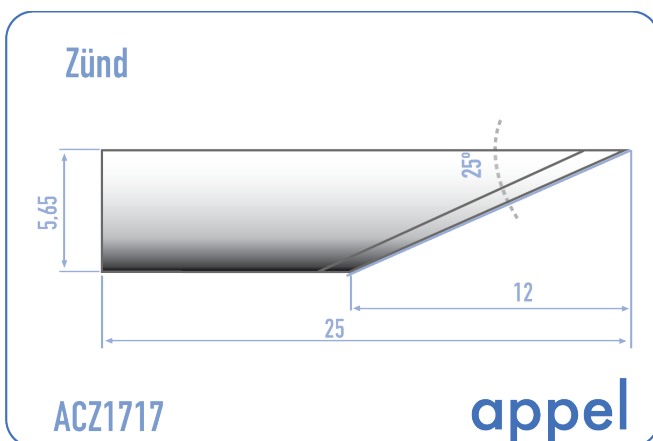
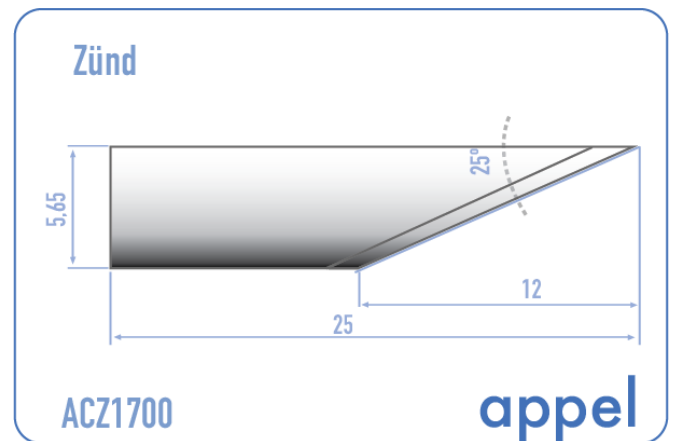

Code / Andere Bezeichnung / Código similar	Z17
Depth of bevel / Schneidtiefe / Profundidad corte	12
Length / Länge / Largo	25
Width / Breite / Ancho	5.65
Thickness / Stärke / Espesor	0.64
Bevel / Schneide / Ángulo	25°
Material / Werkstoff / Material	TC + TiAlN / VHM
Packing unit / VE / Unidad de Venta	2

TC = Tungsteno Carburo



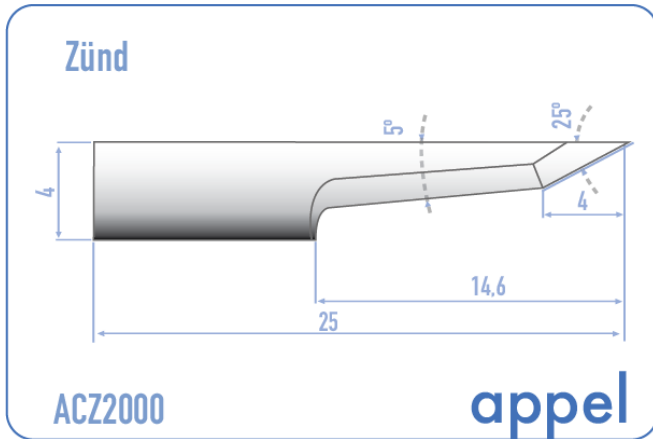

Code / Andere Bezeichnung / Código similar	Z20
Depth of bevel / Schneidtiefe / Profundidad corte	14.3
Length / Länge / Largo	25
Width / Breite / Ancho	4
Thickness / Stärke / Espesor	0.63
Bevel / Schneide / Ángulo	5° / 25°
Material / Werkstoff / Material	TC / VHM
Packing unit / VE / Unidad de Venta	2

TC = Tungsteno Carburo

Code / Andere Bezeichnung / Código similar	Z20
Depth of bevel / Schneidtiefe / Profundidad corte	14.3
Length / Länge / Largo	25
Width / Breite / Ancho	4
Thickness / Stärke / Espesor	0.63
Bevel / Schneide / Ángulo	5° / 25°
Material / Werkstoff / Material	TC + TiAlN / VHM
Packing unit / VE / Unidad de Venta	2

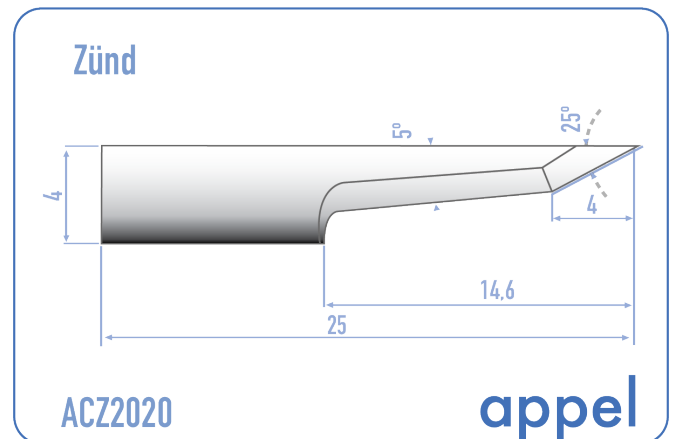

TC = Tungsteno Carburo

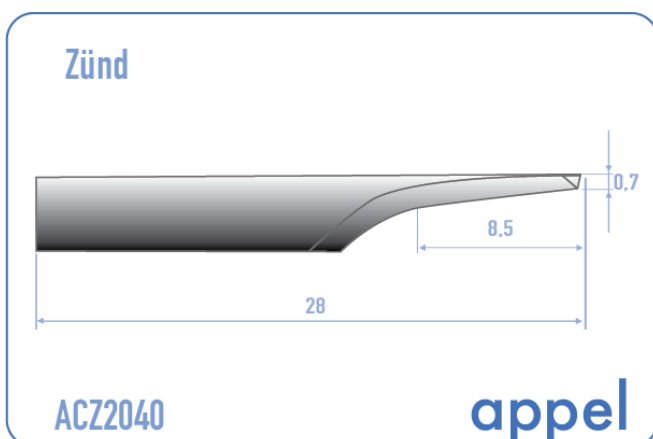

Code / Andere Bezeichnung / Código similar	Z204
Depth of bevel / Schneidtiefe / Profundidad corte	8.5
Length / Länge / Largo	28
Width / Breite / Ancho	
Thickness / Stärke / Espesor	
Bevel / Schneide / Ángulo	
Material / Werkstoff / Material	TC
Packing unit / VE / Unidad de Venta	10

TC = Tungsteno Carburo

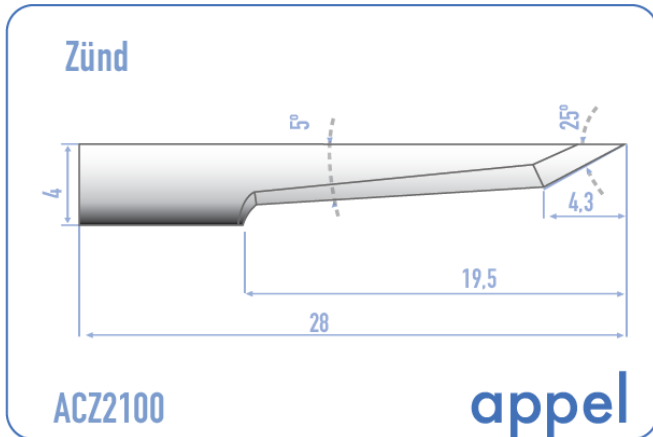

Code / Andere Bezeichnung / Código similar	Z21
Depth of bevel / Schneidtiefe / Profundidad corte	19.5
Length / Länge / Largo	28
Width / Breite / Ancho	4
Thickness / Stärke / Espesor	0.63
Bevel / Schneide / Ángulo	5° / 25°
Material / Werkstoff / Material	TC / VHM
Packing unit / VE / Unidad de Venta	2

TC = Tungsteno Carburo

Code / Andere Bezeichnung / Código similar	Z21
Depth of bevel / Schneidtiefe / Profundidad corte	19.5
Length / Länge / Largo	28
Width / Breite / Ancho	4
Thickness / Stärke / Espesor	0.63
Bevel / Schneide / Ángulo	5° / 25°
Material / Werkstoff / Material	TC + TiAlN / VHM
Packing unit / VE / Unidad de Venta	2

TC = Tungsteno Carburo

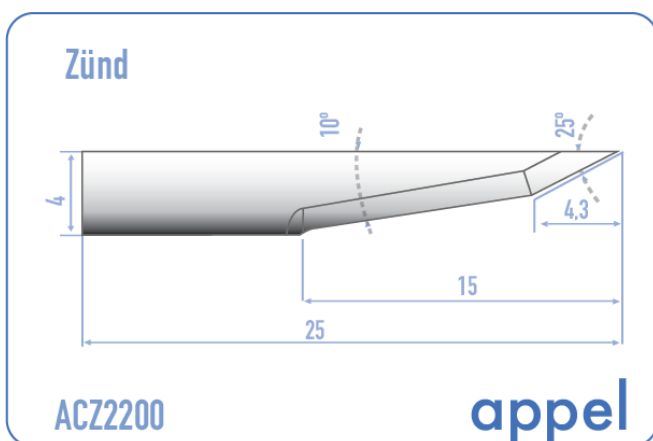
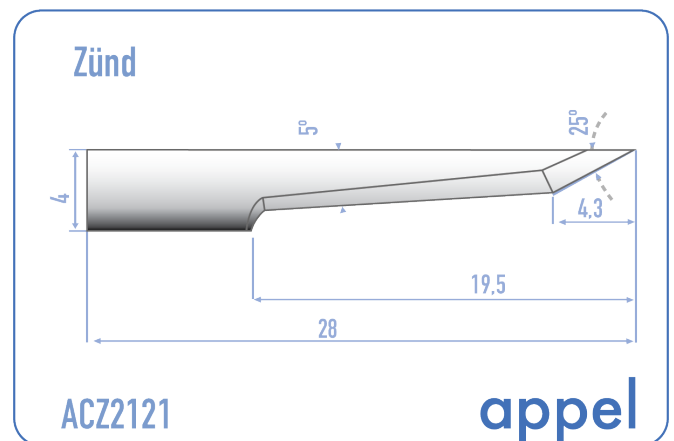

Code / Andere Bezeichnung / Código similar	Z22
Depth of bevel / Schneidtiefe / Profundidad corte	15
Length / Länge / Largo	25
Width / Breite / Ancho	4
Thickness / Stärke / Espesor	0.63
Bevel / Schneide / Ángulo	10° / 25°
Material / Werkstoff / Material	TC / VHM
Packing unit / VE / Unidad de Venta	2

TC = Tungsteno Carburo

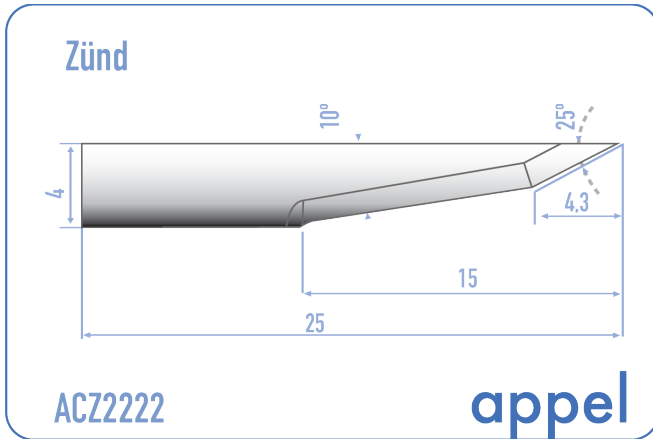

Code / Andere Bezeichnung / Código similar	Z22
Depth of bevel / Schneidtiefe / Profundidad corte	15
Length / Länge / Largo	25
Width / Breite / Ancho	4
Thickness / Stärke / Espesor	0.63
Bevel / Schneide / Ángulo	10° / 25°
Material / Werkstoff / Material	TC + TiAlN / VHM
Packing unit / VE / Unidad de Venta	2

TC = Tungsteno Carburo

Code / Andere Bezeichnung / Código similar	Z23
Depth of bevel / Schneidtiefe / Profundidad corte	22
Length / Länge / Largo	33
Width / Breite / Ancho	4
Thickness / Stärke / Espesor	0.63
Bevel / Schneide / Ángulo	45°
Material / Werkstoff / Material	TC / VHM
Packing unit / VE / Unidad de Venta	2

TC = Tungsteno Carburo

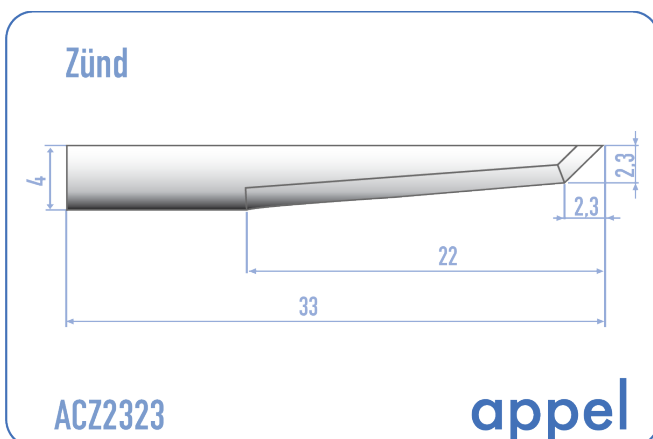
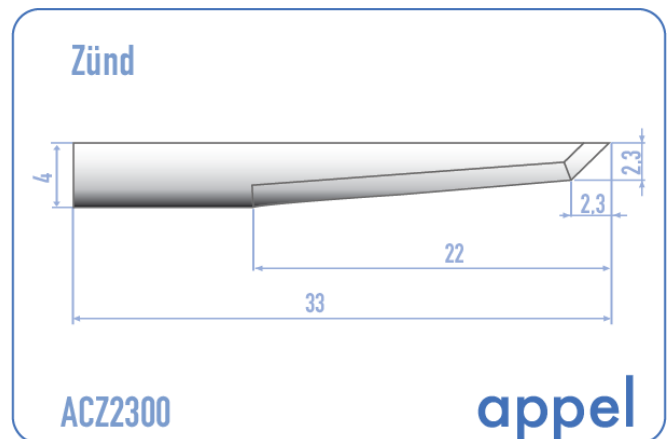

Code / Andere Bezeichnung / Código similar	Z23
Depth of bevel / Schneidtiefe / Profundidad corte	22
Length / Länge / Largo	33
Width / Breite / Ancho	4
Thickness / Stärke / Espesor	0.63
Bevel / Schneide / Ángulo	45°
Material / Werkstoff / Material	TC + TiAlN / VHM
Packing unit / VE / Unidad de Venta	2

TC = Tungsteno Carburo

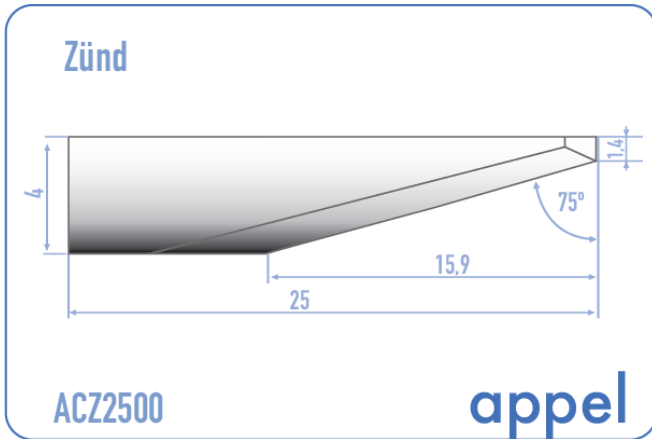

Code / Andere Bezeichnung / Código similar	Z25
Depth of bevel / Schneidtiefe / Profundidad corte	15
Length / Länge / Largo	25
Width / Breite / Ancho	5.65
Thickness / Stärke / Espesor	0.63
Bevel / Schneide / Ángulo	75°
Material / Werkstoff / Material	TC / VHM
Packing unit / VE / Unidad de Venta	2

TC = Tungsteno Carburo

Code / Andere Bezeichnung / Código similar	Z26
Depth of bevel / Schneidtiefe / Profundidad corte	8.7
Length / Länge / Largo	25
Width / Breite / Ancho	5.65
Thickness / Stärke / Espesor	0.63
Bevel / Schneide / Ángulo	12° / 65°
Material / Werkstoff / Material	TC / VHM
Packing unit / VE / Unidad de Venta	2

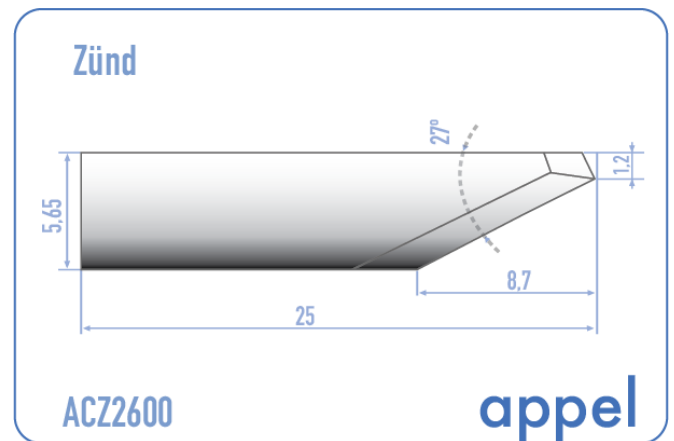

TC = Tungsteno Carburo

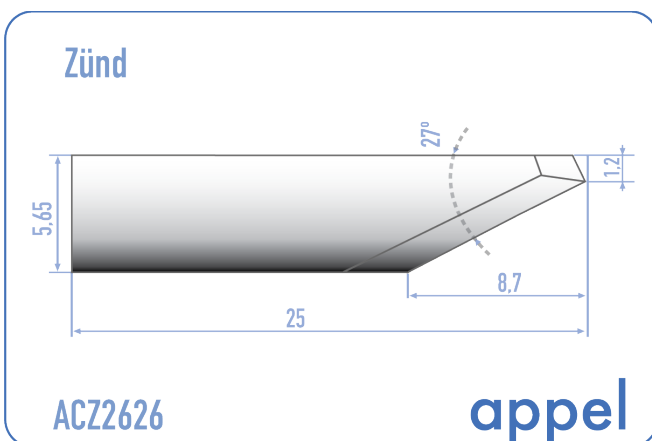

Code / Andere Bezeichnung / Código similar	Z26
Depth of bevel / Schneidtiefe / Profundidad corte	8.7
Length / Länge / Largo	25
Width / Breite / Ancho	5.65
Thickness / Stärke / Espesor	0.63
Bevel / Schneide / Ángulo	12° / 65°
Material / Werkstoff / Material	TC + TiAlN / VHM
Packing unit / VE / Unidad de Venta	2

TC = Tungsteno Carburo

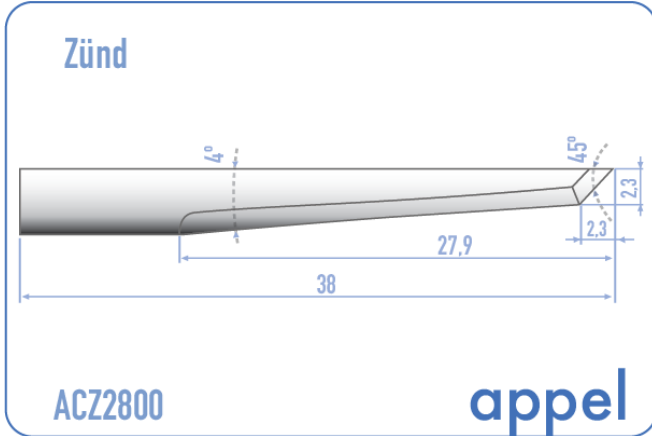

Code / Andere Bezeichnung / Código similar	Z28
Depth of bevel / Schneidtiefe / Profundidad corte	27
Length / Länge / Largo	38
Width / Breite / Ancho	4
Thickness / Stärke / Espesor	0.63
Bevel / Schneide / Ángulo	4° / 45°
Material / Werkstoff / Material	TC / VHM
Packing unit / VE / Unidad de Venta	2

TC = Tungsteno Carbuo

Code / Andere Bezeichnung / Código similar	Z29
Depth of bevel / Schneidtiefe / Profundidad corte	33
Length / Länge / Largo	43.5
Width / Breite / Ancho	4
Thickness / Stärke / Espesor	0.63
Bevel / Schneide / Ángulo	3.5° / 45°
Material / Werkstoff / Material	TC / VHM
Packing unit / VE / Unidad de Venta	2

TC = Tungsteno Carbuo

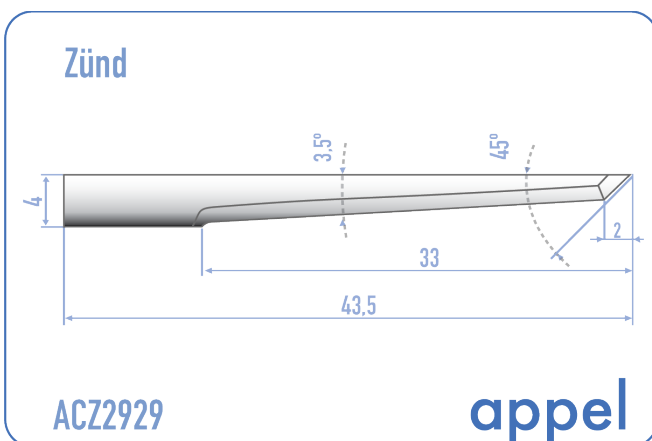
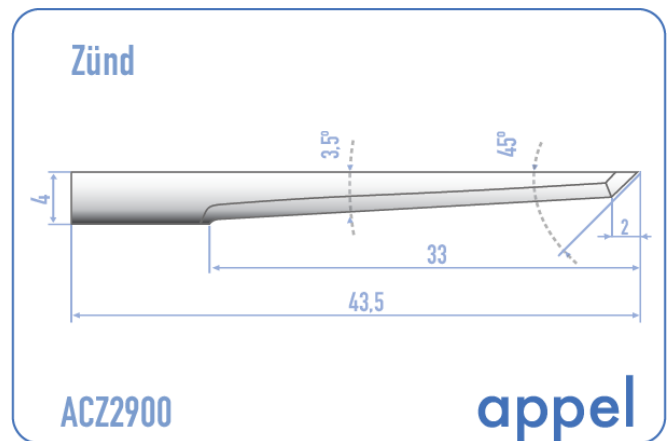

Code / Andere Bezeichnung / Código similar	Z29
Depth of bevel / Schneidtiefe / Profundidad corte	33
Length / Länge / Largo	43.5
Width / Breite / Ancho	4
Thickness / Stärke / Espesor	0.63
Bevel / Schneide / Ángulo	3.5° / 45°
Material / Werkstoff / Material	TC + TiAIN / VHM
Packing unit / VE / Unidad de Venta	2

TC = Tungsteno Carbuo

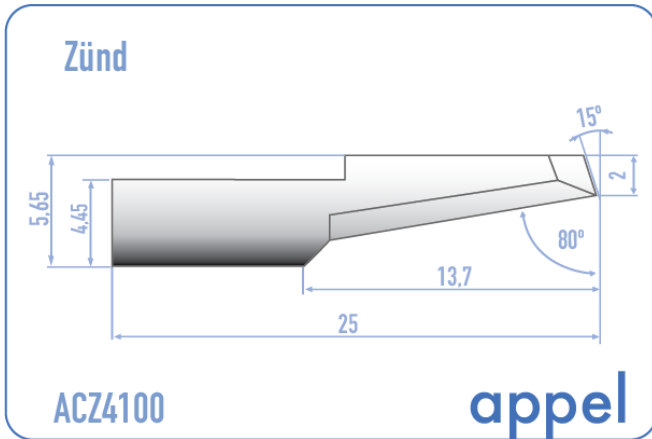

Code / Andere Bezeichnung / Código similar	Z41
Depth of bevel / Schneidtiefe / Profundidad corte	13
Length / Länge / Largo	25
Width / Breite / Ancho	4.45 / 5.65
Thickness / Stärke / Espesor	0.63
Bevel / Schneide / Ángulo	15° / 80°
Material / Werkstoff / Material	TC / VHM
Packing unit / VE / Unidad de Venta	2

TC = Tungsteno Carbuero

Code / Andere Bezeichnung / Código similar	Z41
Depth of bevel / Schneidtiefe / Profundidad corte	13
Length / Länge / Largo	25
Width / Breite / Ancho	4.45 / 5.65
Thickness / Stärke / Espesor	0.63
Bevel / Schneide / Ángulo	15° / 80°
Material / Werkstoff / Material	TC + TiAIN / VHM
Packing unit / VE / Unidad de Venta	2

TC = Tungsteno Carbuero

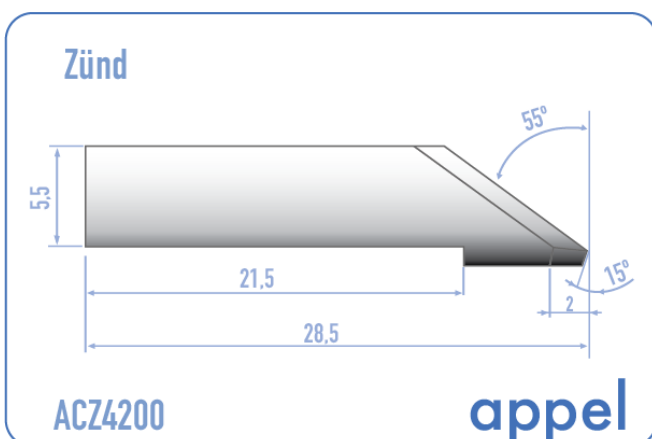
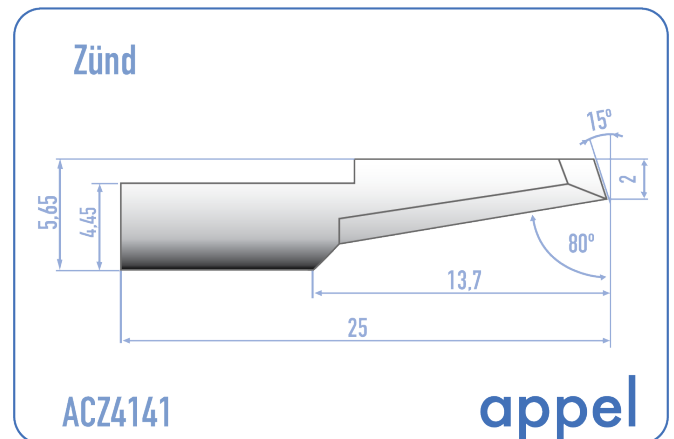

Code / Andere Bezeichnung / Código similar	Z42
Depth of bevel / Schneidtiefe / Profundidad corte	7.8
Length / Länge / Largo	28.5
Width / Breite / Ancho	5.5
Thickness / Stärke / Espesor	0.63
Bevel / Schneide / Ángulo	15° / 55°
Material / Werkstoff / Material	TC / VHM
Packing unit / VE / Unidad de Venta	2

TC = Tungsteno Carbuero

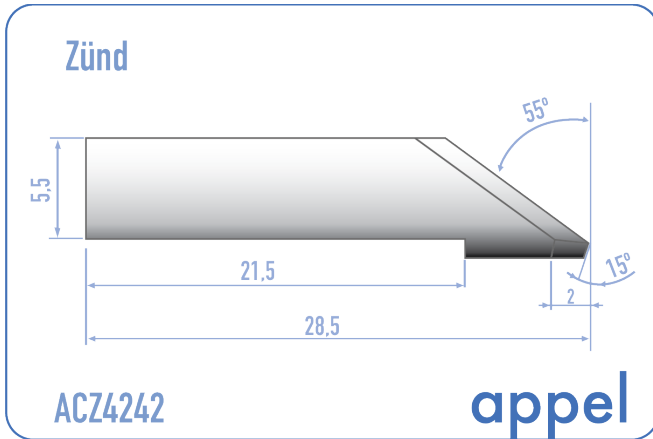

Code / Andere Bezeichnung / Código similar	Z42
Depth of bevel / Schneidtiefe / Profundidad corte	7.8
Length / Länge / Largo	28.5
Width / Breite / Ancho	5.5
Thickness / Stärke / Espesor	0.63
Bevel / Schneide / Ángulo	15° / 55°
Material / Werkstoff / Material	TC + TiAlN / VHM
Packing unit / VE /Unidad de Venta	2

TC = Tungsteno Carburo

Code / Andere Bezeichnung / Código similar	Z43
Depth of bevel / Schneidtiefe / Profundidad corte	7.8
Length / Länge / Largo	28.5
Width / Breite / Ancho	5
Thickness / Stärke / Espesor	0.63
Bevel / Schneide / Ángulo	15° / 55°
Material / Werkstoff / Material	TC / VHM
Packing unit / VE /Unidad de Venta	2

TC = Tungsteno Carburo

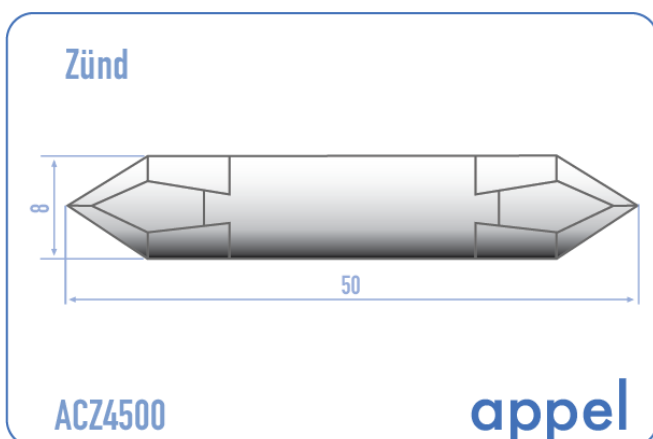
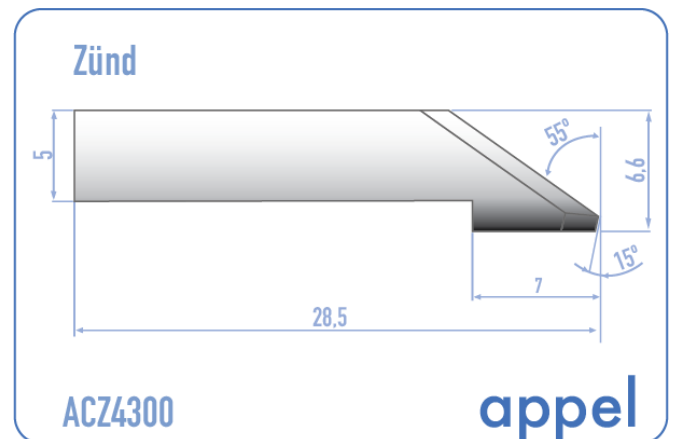

Code / Andere Bezeichnung / Código similar	Z45 DS Z44
Depth of bevel / Schneidtiefe / Profundidad corte	13.7
Length / Länge / Largo	50
Width / Breite / Ancho	8
Thickness / Stärke / Espesor	1.5
Bevel / Schneide / Ángulo	60° / 90°
Material / Werkstoff / Material	TC / VHM
Packing unit / VE /Unidad de Venta	2

TC = Tungsteno Carburo

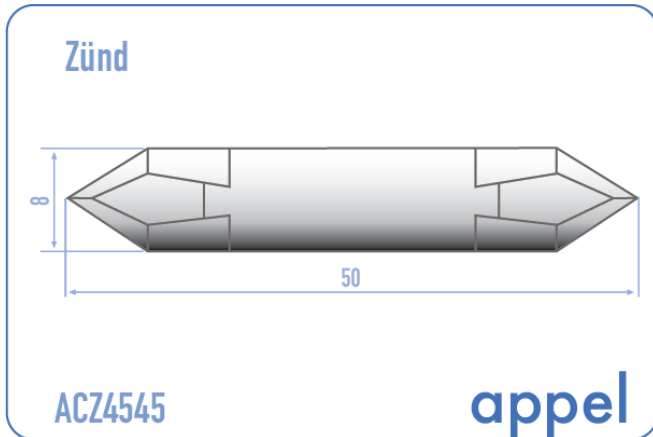

Code / Andere Bezeichnung / Código similar	Z45 DS Z44
Depth of bevel / Schneidtiefe / Profundidad corte	13.7
Length / Länge / Largo	50
Width / Breite / Ancho	8
Thickness / Stärke / Espesor	1.5
Bevel / Schneide / Ángulo	60° / 90°
Material / Werkstoff / Material	TC + TiNIT /VHM
Packing unit / VE /Unidad de Venta	2

TC = Tungsteno Carburo. DS= Double Side

Code / Andere Bezeichnung / Código similar	Z46
Depth of bevel / Schneidtiefe / Profundidad corte	20.5
Length / Länge / Largo	50
Width / Breite / Ancho	6 : 8
Thickness / Stärke / Espesor	1.5
Bevel / Schneide / Ángulo	45°
Material / Werkstoff / Material	TC / VHM
Packing unit / VE /Unidad de Venta	2

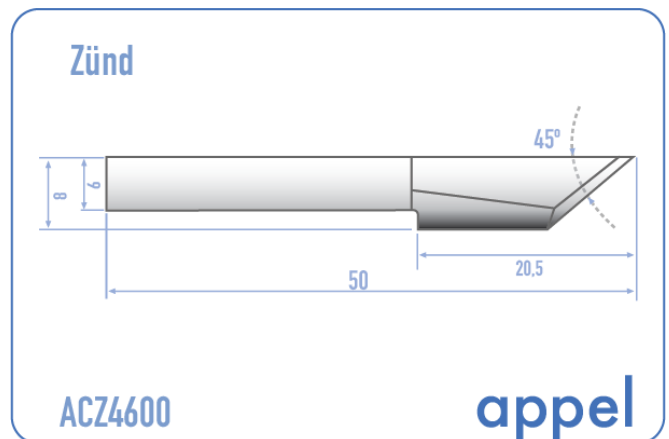

TC = Tungsteno Carburo. DS= Double Side

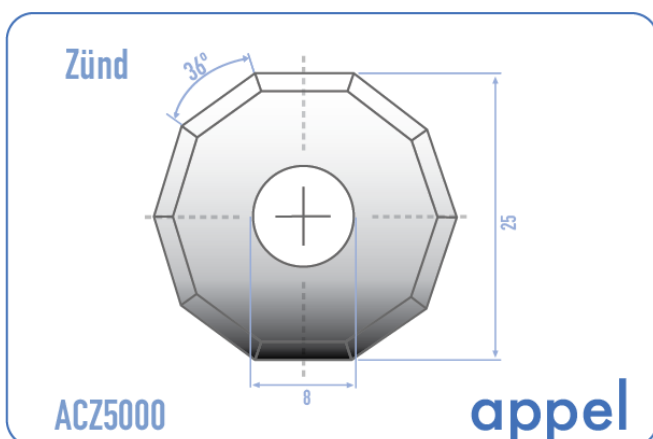

Code / Andere Bezeichnung / Código similar	Z50
Depth of bevel / Schneidtiefe / Profundidad corte	3.5
Length / Länge / Largo	25
Width / Breite / Ancho	
Thickness / Stärke / Espesor	0.63
Bevel / Schneide / Ángulo	
Material / Werkstoff / Material	TC / VHM
Packing unit / VE /Unidad de Venta	2

TC = Tungsteno Carburo



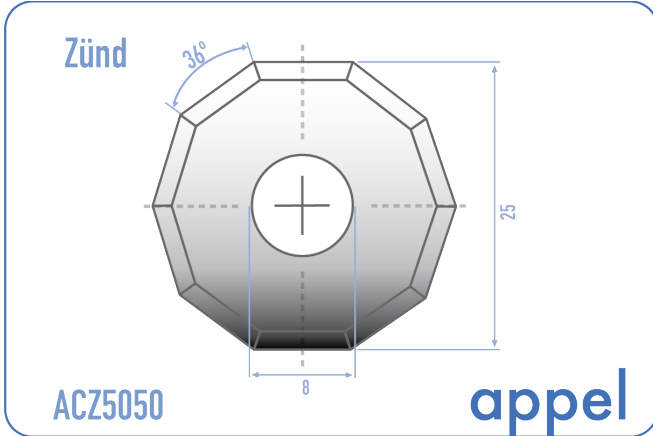

Code / Andere Bezeichnung / Código similar	Z50
Depth of bevel / Schneidtiefe / Profundidad corte	3.5
Length / Länge / Largo	25
Width / Breite / Ancho	
Thickness / Stärke / Espesor	0.63
Bevel / Schneide / Ángulo	
Material / Werkstoff / Material	TC + TiNII/VHM
Packing unit / VE /Unidad de Venta	2

TC = Tungsteno Carburo

Code / Andere Bezeichnung / Código similar	Z51
Depth of bevel / Schneidtiefe / Profundidad corte	
Length / Länge / Largo	28
Width / Breite / Ancho	
Thickness / Stärke / Espesor	0.62
Bevel / Schneide / Ángulo	
Material / Werkstoff / Material	TC / VHM
Packing unit / VE /Unidad de Venta	2

TC = Tungsteno Carburo

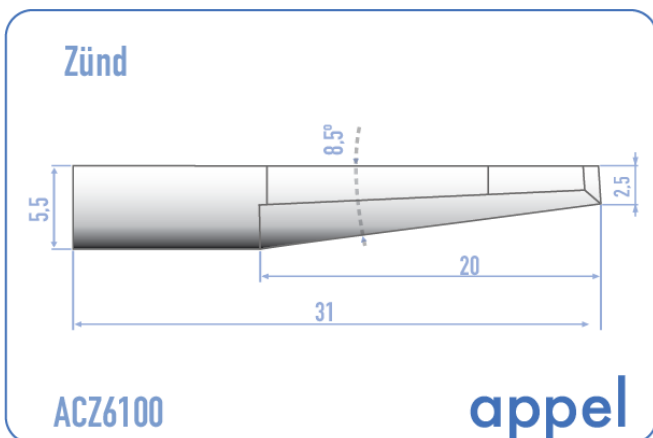
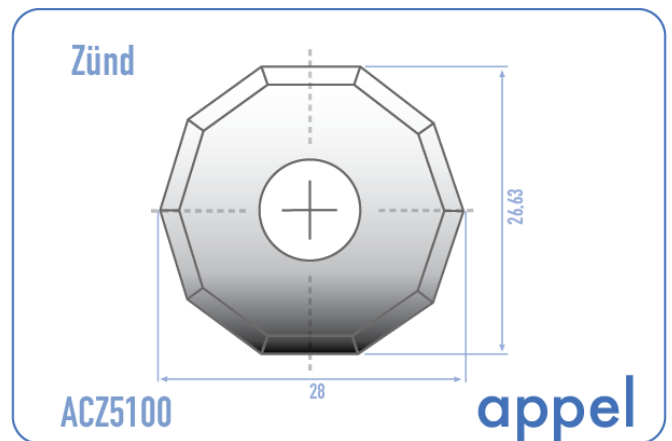

Code / Andere Bezeichnung / Código similar	Z61
Depth of bevel / Schneidtiefe / Profundidad corte	20
Length / Länge / Largo	31
Width / Breite / Ancho	5.5
Thickness / Stärke / Espesor	5.5
Bevel / Schneide / Ángulo	5° / 81°
Material / Werkstoff / Material	TC / VHM
Packing unit / VE /Unidad de Venta	2

TC = Tungsteno Carburo

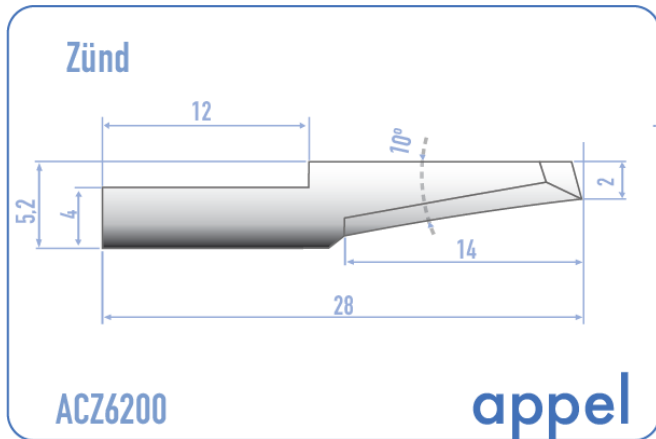

Code / Andere Bezeichnung / Código similar	Z62
Depth of bevel / Schneidtiefe / Profundidad corte	13.2
Length / Länge / Largo	28
Width / Breite / Ancho	4 / 5.2
Thickness / Stärke / Espesor	0.63
Bevel / Schneide / Ángulo	10°
Material / Werkstoff / Material	TC / VHM
Packing unit / VE /Unidad de Venta	2

TC = Tungsteno Carburo

Code / Andere Bezeichnung / Código similar	Z63
Depth of bevel / Schneidtiefe / Profundidad corte	29
Length / Länge / Largo	43
Width / Breite / Ancho	4.45 / 5.65
Thickness / Stärke / Espesor	0.63
Bevel / Schneide / Ángulo	15° / 83°
Material / Werkstoff / Material	TC / VHM
Packing unit / VE /Unidad de Venta	2

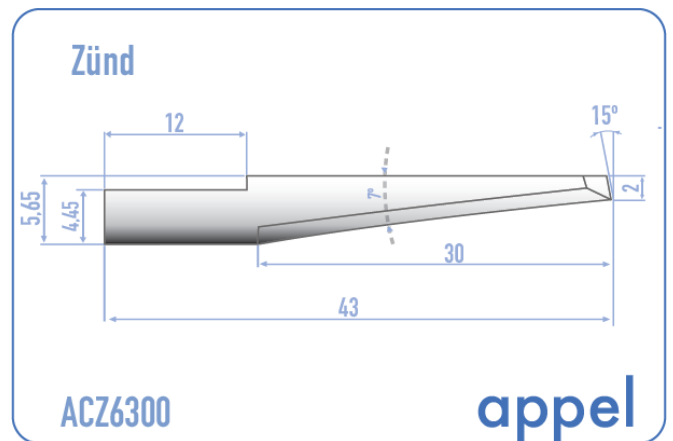

TC = Tungsteno Carburo

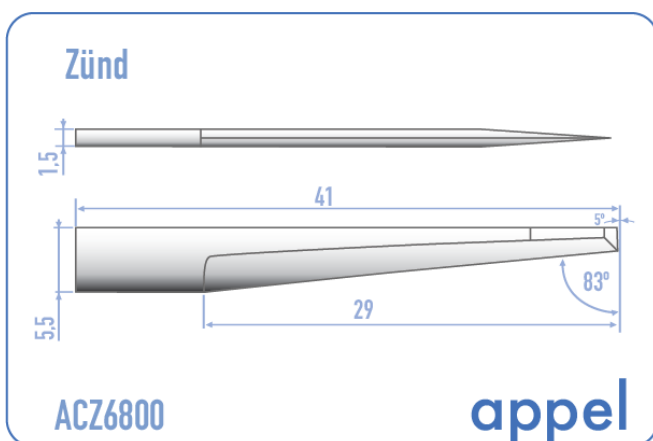

Code / Andere Bezeichnung / Código similar	Z68
Depth of bevel / Schneidtiefe / Profundidad corte	29
Length / Länge / Largo	41.5
Width / Breite / Ancho	5.5
Thickness / Stärke / Espesor	5.5
Bevel / Schneide / Ángulo	5° / 83°
Material / Werkstoff / Material	TC / VHM
Packing unit / VE /Unidad de Venta	2

TC = Tungsteno Carburo

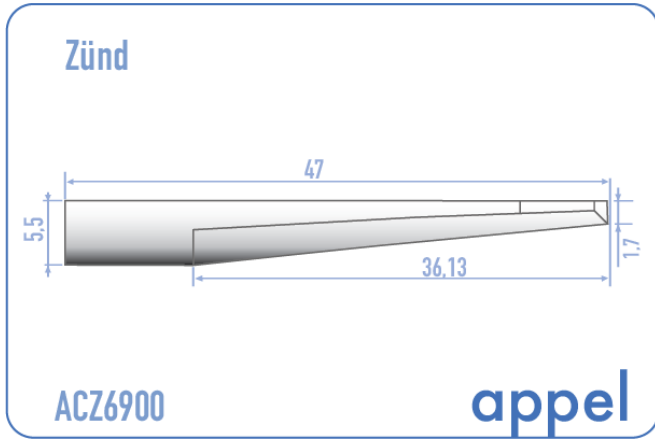

Code / Andere Bezeichnung / Código similar	<b>Z69</b>
Depth of bevel / Schneidtiefe / Profundidad corte	<b>36.1</b>
Length / Länge / Largo	<b>47</b>
Width / Breite / Ancho	<b>5.5</b>
Thickness / Stärke / Espesor	<b>0.54</b>
Bevel / Schneide / Ángulo	
Material / Werkstoff / Material	<b>TC / VHM</b>
Packing unit / VE /Unidad de Venta	<b>2</b>

TC = Tungsteno Carburo

Code / Andere Bezeichnung / Código similar	<b>Z73</b>
Depth of bevel / Schneidtiefe / Profundidad corte	
Length / Länge / Largo	<b>60</b>
Width / Breite / Ancho	<b>19</b>
Thickness / Stärke / Espesor	<b>0.9</b>
Bevel / Schneide / Ángulo	
Material / Werkstoff / Material	<b>Acero</b>
Packing unit / VE /Unidad de Venta	<b>50</b>

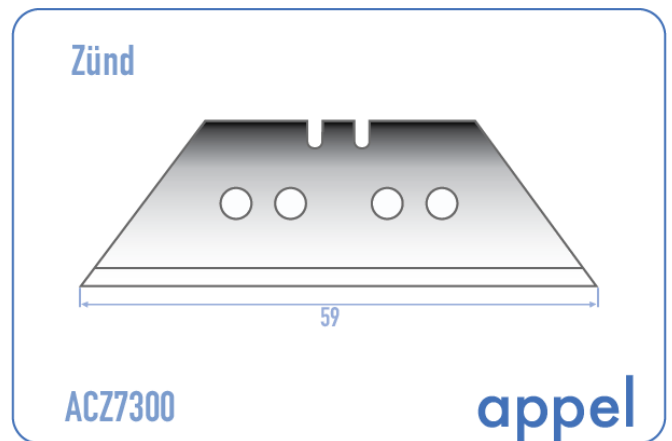

TC = Tungsteno Carburo

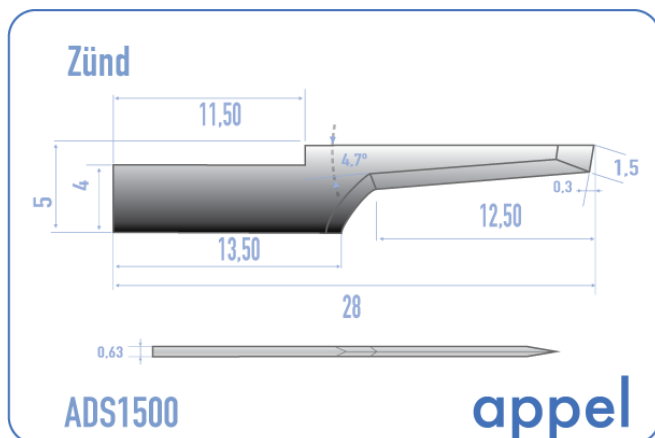

Code / Andere Bezeichnung / Código similar	<b>DS-15</b>
Depth of bevel / Schneidtiefe / Profundidad corte	<b>12,50</b>
Length / Länge / Largo	<b>28</b>
Width / Breite / Ancho	<b>4 / 5</b>
Thickness / Stärke / Espesor	<b>0.63</b>
Bevel / Schneide / Ángulo	<b>4,7°</b>
Material / Werkstoff / Material	<b>TC</b>
Packing unit / VE /Unidad de Venta	<b>10</b>

TC = Tungsteno Carburo

# appel

---

Appel Group

## Contact / Kontakt / Contacto

**Appel Schneidtechnik GmbH**  
**Marderweg 15, 73230**  
**Kirchheim / Teck, Germany**

**info@appelgroup.eu**

**Skype: Francisco.Appel**

**Cel: +49 171 30 46 395**

**Tel: +49 7021 978 424**

**Fax: +49 7021 978 426**



[www.appelgroup.eu](http://www.appelgroup.eu)